



# ASI 35

Modular tracer gas leak detector

The highest performance in helium and hydrogen for industrial leak detection systems.

**PFEIFFER**  **VACUUM**



# ASI 35

## Modular tracer gas leak detector

The highest performance in helium and hydrogen for industrial leak detection systems.

### The perfect solution

The ASI 35 is the perfect leak detection solution dedicated to leak detection machine builders and end-users. This unit combines high performance, reliability, and repeatability with maximum uptime. The ASI 35 provides maximum performance for tracer gases helium and hydrogen in integral and localizing test methods or a combination of both. Therefore, it offers flexibility in the testing of demanding samples with minimum signal background and crosstalk, guaranteeing fast overall cycle times.

### Flexible and versatile

Due to its modular design, the ASI 35 is optimized for minimum space requirements and maximum integration options. The vacuum module can be installed in any orientation and all other modules are compatible with 1/2 19 inch rack format. The user interface becomes optional as the unit can be controlled by PCs or PLCs. Only two cables are needed to connect the vacuum and electronic modules, making the ASI 35 the easiest modular leak detector to set up.



Automotive



Refrigeration and air conditioning



Packaging industry



## Applications

- Automotive: airbag inflators and ignitors, cooling radiators, fuel rails, and injectors
- Refrigeration and air conditioning: evaporators, compressors, tubes, coils
- Packaging: cans and capsules, tubular bags, blisters
- Mechanical parts: valves, fittings, manifolds

# ASI 35

## Modular tracer gas leak detector

The highest performance in helium and hydrogen for industrial leak detection systems.

### Dependable, fast, and sensitive

Further advantages of the ASI 35 are its high helium pumping speed and low maintenance turbopump, its dual independent long life filaments as well as its state-of-the-art electronics. These features guarantee a long-lasting trouble-free operation. The leak detection system can be designed for testing in various operational modes for vacuum or sniffing tests with the highest sensitivity level. The ASI 35 sustains very high throughput, ensures the accuracy and reproducibility of the measurement results and allows ultra fast cycle time as short as 1 second. Thanks to its unrivalled performances in sniffing, the ASI 35 is the perfect leak detector for such specific systems, especially if multipoint sniffing is needed.

### Easy worldwide operation

The electronic module is suitable for universal voltage, making the ASI 35 easy to integrate into systems designated for worldwide operation. The leak detector is designed for working conditions in ambient temperatures of up to 45 °C. The easy mechanical integration is complemented by a wide range of interfaces, allowing data acquisition and complete external control of the system. Thanks to customized I/O configuration, a basic leak detection system can also be considered without PC or PLC. The optional control panel with color touch display provides easy operation through intuitive settings and software menus for both leak detection machine builders and end-users.

### Customer benefits:

- Integral and localizing test (vacuum and sniffing) for both tracer gases: helium and hydrogen
- Short cycle times due to highest pumping speed
- Maximum reliability and robustness for high uptime
- Wide temperature range allows for operation in challenging environments
- Worldwide operation thanks to universal voltage of the electronic module
- Ability to sustain up to 800 sccm flow in sniffing applications
- Easy substitution of any other modular leak detector model (I/O compatibility mode)

## Dimensions

### Vacuum module

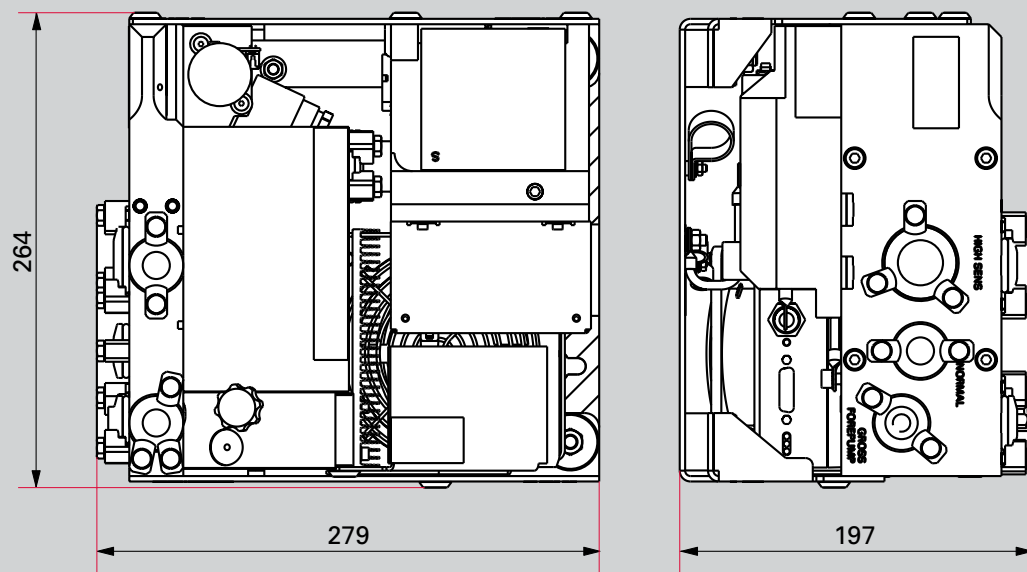

### Electronic module

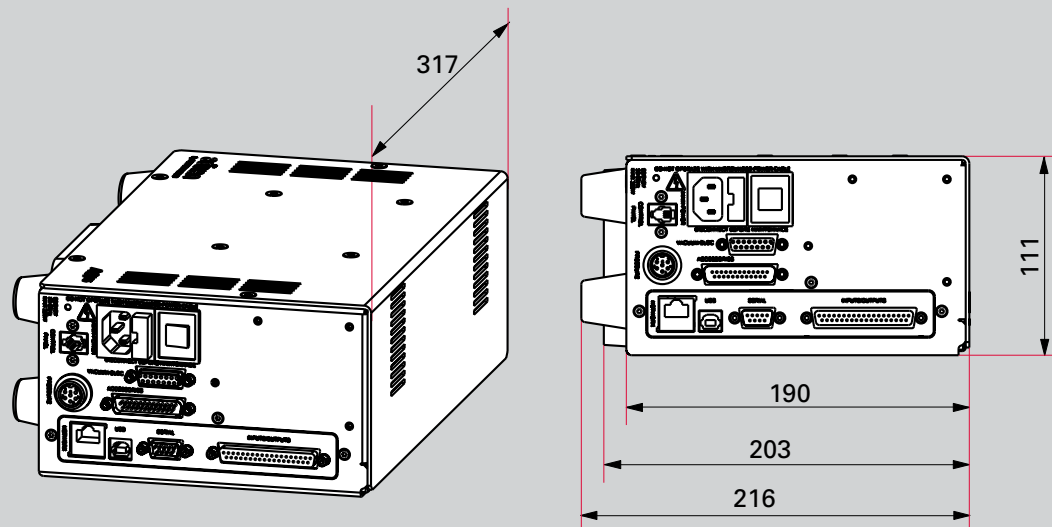

### Control panel

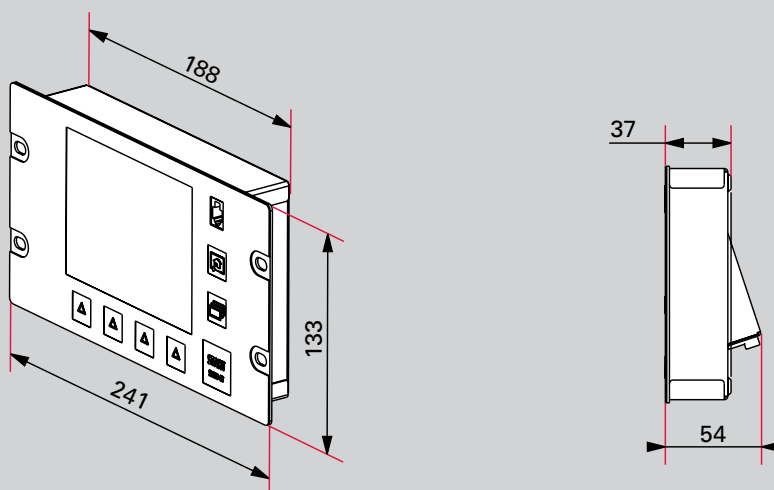

Dimensions in mm

# ASI 35

## Technical data and order numbers

### Technical data

Modular helium leak detector	ASI 35
Test methods	Vacuum and sniffing leak detection
Minimum detectable leak rate for He (vacuum leak detection)	3.5 · 10 <sup>-8</sup> mbar l/s (gross leak test mode) 1 · 10 <sup>-10</sup> mbar l/s (normal leak test mode) 5 · 10 <sup>-12</sup> mbar l/s (high sensitivity test mode)
Minimum detectable leak rate for He (sniffing leak detection)	1.5 · 10 <sup>-8</sup> mbar l/s
Tracer gases	<sup>4</sup> He, <sup>3</sup> He, H <sub>2</sub>
Maximum inlet test pressure	18 mbar (gross leak test mode) 1 mbar (normal leak test mode) 0.2 mbar (high sensitivity test mode)
Pumping speed for He	6 l/s (high sensitivity test mode) 1.8 l/s (normal test mode)
Start-up time	< 3 min
Vacuum connections	DN 25 ISO-KF; DN 16 ISO-KF
Interface (see the order matrix for complete options configuration)	RS-232 Ethernet Profibus USB
I/O interface	6 digital inputs (allocated functions configurable) 3 analog outputs (configurable: helium signal log, mantissa, exponent, inlet pressure) 5 relay outputs (allocated functions configurable) 4 transistor (open collector) outputs (allocated functions configurable)
Dimensions: L × W × H	
Vacuum module:	279 × 264 × 197 mm
Electronic module:	216 × 317 × 111 mm
Control panel:	241 × 54 × 133 mm
Weight	
Vacuum module:	15 kg
Electronic module:	5 kg
Control panel:	1.3 kg
Universal Voltage	90–240 V AC; 50/60 Hz
Maximum power consumption	300 W
Operating temperature	10–45 °C

**Industrial control panel and associated cable length a**

Without control panel	0
1.8 m	1
5 m	2
10 m	3

**Cable length for electronic module b**

1.5 m	1
3.5 m	2
5 m	3
10 m	4

**Sniffing c**

Without	X
With	S

**Internal calibration d**

Without	0
With	1

**Interface board e**

37 pins I/O	2
37 pins I/O + Ethernet	4
Profibus	6

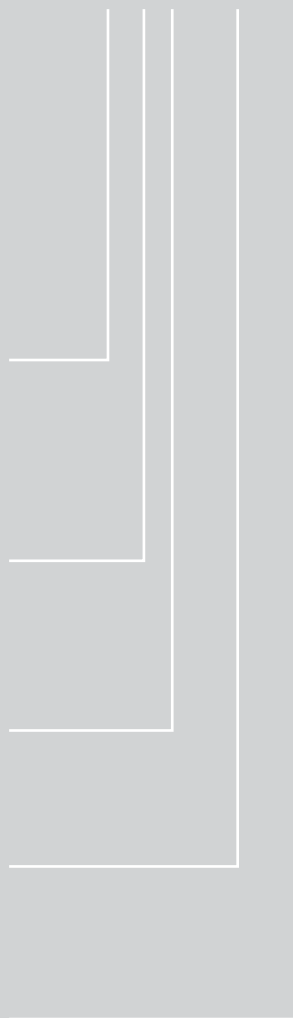

**Order numbers accessories**

Accessories	Order number
<b>Sniffing option</b>	
Sniffing kit	123529
<b>Calibration</b>	
Calibration kit	123530
<b>Sniffing probe</b>	
Rigid 9 cm nozzle, 5 m tube length (Other nozzle and tube lengths upon request)	SNC1E1T1
<b>Specific communication interface</b>	
I/O module type ASI 20 MD	123352

## VACUUM SOLUTIONS FROM A SINGLE SOURCE

Pfeiffer Vacuum stands for innovative and custom vacuum solutions worldwide, technological perfection, competent advice and reliable service.

## COMPLETE RANGE OF PRODUCTS

From a single component to complex systems:

We are the only supplier of vacuum technology that provides a complete product portfolio.

## COMPETENCE IN THEORY AND PRACTICE

Benefit from our know-how and our portfolio of training opportunities!

We support you with your plant layout and provide first-class on-site service worldwide.

Are you looking for a  
perfect vacuum solution?  
Please contact us:

Pfeiffer Vacuum GmbH  
Headquarters · Germany  
T +49 6441 802-0  
info@pfeiffer-vacuum.de

[www.pfeiffer-vacuum.com](http://www.pfeiffer-vacuum.com)

All information is subject to change without prior notice. PL 0098 PEN (January 2016)

**PFEIFFER**  **VACUUM**

